

**INSTITUTO DE CIENCIAS
DE LA CONSTRUCCIÓN
EDUARDO TORROJA**

C/ Serrano Galvache n. 4 28033 Madrid (Spain)
Tel.: (34) 91 302 04 40 Fax: (34) 91 302 07 00
direccion.ietcc@csic.es <https://dit.ietcc.csic.es>

European Technical Assessment

**ETA 17/0830
of 11/04/2019**

English translation prepared by IETcc. Original version in Spanish language

General Part

Technical Assessment Body issuing the ETA designated according to Art. 29 of Regulation (EU) 305/2011:

Instituto de Ciencias de la Construcción Eduardo Torroja (IETcc)

Trade name of the construction product:

**Anchor S-Fix Plus / Slim Fix
Anchor S-Fix Plus A2
Anchor S-Fix Plus A4**

Product family to which the construction product belongs:

Torque controlled expansion anchor made of galvanised steel or stainless steel of sizes M6, M8, M10, M12, M14, M16 and M20 for use in non-cracked concrete.

Manufacturer:

TOX-Dübel-Technik GmbH
Brunnenstraße 31
72505 Krauchenwies-Ablach, Germany.
website: www.tox.de

Manufacturing plants:

ETA holder plant 1
ETA holder plant 2

This European Technical Assessment contains:

13 pages including 4 annexes which form an integral part of this assessment.

This European Technical Assessment is issued in accordance with regulation (EU) No 305/2011, on the basis of:

European Technical Assessment EAD 330232-00-0601 "Mechanical Fasteners for use in concrete", ed. October 2016

This version replaces:

ETA 17/0830 issued on 06/02/2018

English translation prepared by IETcc

This European Technical Assessment is issued by the Technical Assessment Body in its official language. Translations of this European Technical Assessment in other languages shall fully correspond to the original issued document and should be identified as such.

This European Technical Assessment may be withdrawn by the issuing Technical Assessment Body, in particular pursuant to information by the Commission according to article 25 (3) of Regulation (EU) No 305/2011.

SPECIFIC PART

1. Technical description of the product

The S-Fix Plus / Slim Fix in the range of M6, M8, M10, M12, M14, M16 and M20 is an anchor made of galvanised steel. The S-Fix Plus A2 and S-Fix Plus A4 in the range of M6, M8, M10, M12, M16 and M20 are anchors made of stainless steel of grades A2 and A4 respectively. The anchor is installed into a predrilled cylindrical hole and anchored by torque-controlled expansion. The anchorage is characterised by friction between expansion clip and concrete.

Product and installation descriptions are given in annexes A1 and A2.

2. Specification of the intended use in accordance with the applicable European Assessment Document.

The performances given in section 3 are only valid if the anchor is used in compliance with the specifications and conditions given in annex B.

The verifications and assessment methods on which this European Technical Assessment is based lead to the assumption of a working life of the anchor of at least 50 years. The indications given on the working life cannot be interpreted as a guarantee given by the producer, but are to be regarded only as a mean to choosing the right products in relation to the expected economically reasonable working life of the works.

3. Performance of the product and references to the methods used for its assessment

3.1 Mechanical resistance and stability (BWR 1)

Essential characteristic	Performance
S-Fix Plus / Slim Fix product performance for static or quasi static actions	See annex C
S-Fix Plus A2 and S-Fix Plus A4 product performance for static or quasi static actions	See annex D

3.2 Safety in case of fire (BWR 2)

Essential characteristic	Performance
Reaction to fire	Anchorage satisfy requirements for class A1
Resistance to fire	No performance assessed

4. Assessment and verification of constancy of performance (hereinafter AVCP) system applied, with reference to its legal base

The applicable European legal act for the system of Assessment and Verification of Constancy of Performances (see annex V of Regulation (EU) No 305/2011) is 96/582/EC.

The system to be applied is 1.

English translation prepared by IETcc

5. Technical details necessary for the implementation of the AVCP system, as provided for in the applicable European Assessment Document.

The technical details necessary for the implementation of the AVCP system are laid down in the quality plan deposited at Instituto de Ciencias de la Construcción Eduardo Torroja.



Instituto de Ciencias de la Construcción Eduardo Torroja
CONSEJO SUPERIOR DE INVESTIGACIONES CIENTÍFICAS

C/ Serrano Galvache n.º 4. 28033 Madrid.
Tel: (+34) 91 302 04 40 Fax: (+34) 91 302 07 00
<https://: dit.ietcc.csic.es>



On behalf of the Instituto de Ciencias de la Construcción Eduardo Torroja
Madrid, 11th of April 2019



Director

Product and identification

S-Fix Plus / Slim Fix, S-Fix Plus A2, S-Fix Plus A4 anchor

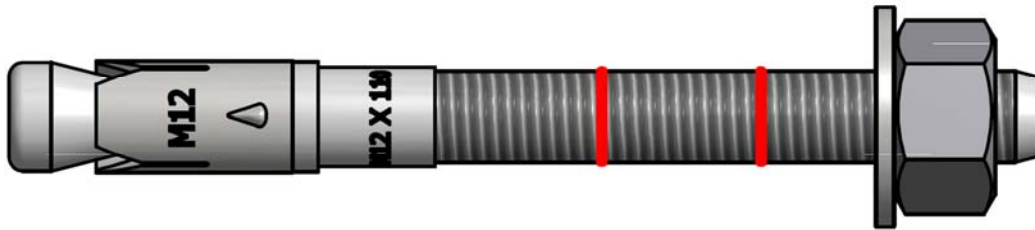

Identification on anchor:

- Expansion clip:
 - Anchor S-Fix Plus / Slim Fix: Company logo + “Opt.7” + Metric size.
 - Anchor S-Fix Plus A2: Company logo + “Fix A2” + Metric size.
 - Anchor S-Fix Plus A4: Company logo + “Fix A4” + Metric size.
- Anchor body: Metric x Length
- Red ring marks to show embedment depths
- Anchor length letter code on the tip:

Letter code	Length [mm]
B	51 ÷ 62
C	63 ÷ 75
D	76 ÷ 88
E	89 ÷ 101
F	102 ÷ 113
G	114 ÷ 126
H	127 ÷ 139
I	140 ÷ 151
J	152 ÷ 164
K	165 ÷ 177
L	178 ÷ 190
M	191 ÷ 202
N	203 ÷ 215
P	229 ÷ 240
Q	241 ÷ 253
R	254 ÷ 266
S	267 ÷ 300

S-Fix Plus / Slim Fix, S-Fix Plus A2, S-Fix Plus A4 anchor	Annex A1
Product description	
Identification.	

English translation prepared by IETcc

Installed condition

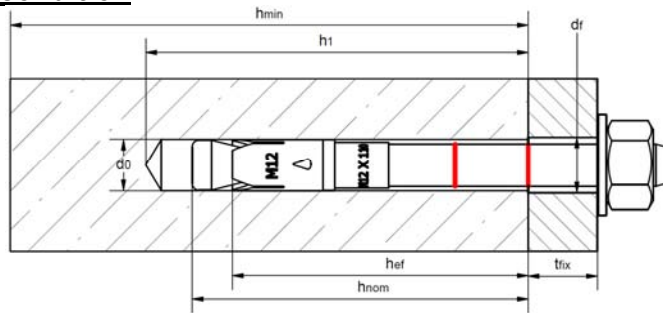

Standard embedment depth (all sizes)

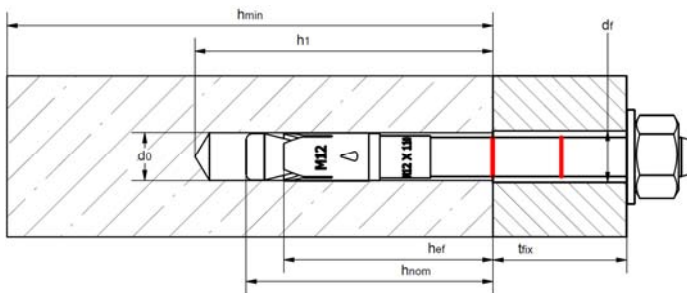

Reduced embedment depth (sizes M8, M10, M12, M16 and M20)

- d_0 : Nominal diameter of drill bit
- d_f : Fixture clearance hole diameter
- h_{ef} : Effective anchorage depth
- h_1 : Depth of drilled hole
- h_{nom} : Overall anchor embedment depth in the concrete
- h_{min} : Minimum thickness of concrete member
- t_{fix} : Fixture thickness
- T_{ins} : Installation torque

Table A1: Materials

Item	Designation	Material for S-Fix Plus / Slim Fix	Material for S-Fix Plus A2	Material for S-Fix Plus A4
1	Anchor Body	Carbon steel galvanised $\geq 5 \mu\text{m}$ ISO 4042 A2, cold forged	Stainless steel, grade A2	Stainless steel, grade A4
2	Washer	DIN 125, DIN 9021 or DIN 440 galvanised $\geq 5 \mu\text{m}$ ISO 4042 A2	DIN 125, DIN 9021 or DIN 440, stainless steel grade A2	DIN 125, DIN 9021 or DIN 440, stainless steel grade A4
3	Nut	DIN 934 class 6 galvanised $\geq 5 \mu\text{m}$ ISO 4042 A2, class 6	DIN 934, stainless steel grade A2	DIN 934, stainless steel grade A4
4	Expansion clip	Carbon steel galvanised $\geq 5 \mu\text{m}$ ISO 4042 A2	Stainless steel, grade A2	Stainless steel, grade A4

S-Fix Plus / Slim Fix, S-Fix Plus A2, S-Fix Plus A4 anchor	Annex A2
Product description Installed condition and materials.	

Intended use

Anchorage subjected to:

- Static or quasi static loads: all sizes and embedment depths

Base materials:

- Reinforced and unreinforced concrete according to EN 206-1
- Strength classes C20/25 to C50/60 according to EN 206-1
- Uncracked concrete

Use conditions (environmental conditions):

- The anchor shall be used in dry internal conditions: all anchor types
- Structural subjected to external atmospheric exposure (including industrial and marine environment) and to permanent internal conditions with no particular aggressive conditions exists: screw types made of stainless steel with marking A4. Such particular aggressive conditions are e.g. permanent, alternating immersion in seawater or the splash zone of seawater, chloride atmosphere of indoor swimming pools or atmosphere with extreme chemical pollution (e.g. in desulphurization plants or road tunnels where de-icing materials are used).

Design:

- Anchorages are designed under the responsibility of an engineer experienced in anchorages and concrete.
- Verifiable calculation rules and drawings are prepared taking into account of the loads to be attached. The position of the anchor is indicated on the design drawings (e.g. position of the anchor relative to reinforcement or to supports, etc.)
- Anchorages under static or quasi-static loads are designed for design Method A in accordance with:
 - EN 1992-4:2018
- Size M8 in reduced embedment depth is restricted to anchoring of structural components which are statically indeterminate.

Installation:

- Hammer drilling only.
- Anchor installation carried out by appropriately qualified personal and under the supervision of the person responsible for technical matters of the site.
- In case of aborted hole: new drilling at a minimum distance away of twice the depth of aborted hole or smaller distance if the aborted hole is filled with high strength mortar and if under shear or oblique tension load it is not the direction of the load application.

S-Fix Plus / Slim Fix, S-Fix Plus A2, S-Fix Plus A4 anchor		Annex B1
Intended use		
Specifications.		

Table C1: Installation parameters for S-Fix Plus / Slim Fix anchor

S-Fix Plus / Slim Fix: GALVANISED ANCHOR Installation parameters			Performances						
			M6	M8	M10	M12	M14	M16	M20
d_0	Nominal diameter of drill bit:	[mm]	6	8	10	12	14	16	20
d_f	Fixture clearance hole diameter:	[mm]	7	9	12	14	16	18	22
T_{inst}	Nominal installation torque:	[Nm]	7	20	35	60	90	120	240
Standard embedment depth									
L_{min}	Minimum length of the bolt:	[mm]	60	75	85	100	115	125	160
h_{min}	Minimum thickness of concrete member:	[mm]	100	100	110	130	150	168	206
h_1	Depth of drilled hole \geq	[mm]	55	65	75	85	100	110	135
h_{nom}	Overall anchor embed depth in concrete:	[mm]	49.5	59.5	66.5	77	91	103.5	125
$h_{ef, std}$	Effective anchorage depth:	[mm]	40	48	55	65	75	84	103
t_{fix}	Thickness of fixture for DIN 125 washer \leq	[mm]	L-58	L-70	L-80	L-92	L-108	L-122	L-147
t_{fix}	Thickness of fixture for DIN 9021 or DIN 440 washer \leq	[mm]	L-58	L-71	L-80	L-94	L-108	L-124	L-149
s_{min}	Minimum allowable spacing:	[mm]	35	40	50	70	80	90	135
c_{min}	Minimum allowable distance:	[mm]	35	40	50	70	80	90	135
Reduced embedment depth									
L_{min}	Minimum length of the bolt:	[mm]	--	60	70	80	--	110	130
h_{min}	Minimum thickness of concrete member:	[mm]	--	100	100	100	--	130	150
h_1	Depth of drilled hole:	[mm]	--	50	60	70	--	90	107
h_{nom}	Overall anchor embed depth in concrete:	[mm]	--	46.5	53.5	62	--	84.5	97
$h_{ef, red}$	Effective anchorage depth:	[mm]	--	35	42	50	--	65	75
t_{fix}	Thickness of fixture for DIN 125 washer \leq	[mm]	--	L-57	L-67	L-77	--	L-103	L-121
t_{fix}	Thickness of fixture for DIN 9021 or DIN 440 washer \leq	[mm]	--	L-58	L-67	L-79	--	L-105	L-123
s_{min}	Minimum allowable spacing:	[mm]	--	40	50	70	--	90	135
c_{min}	Minimum allowable distance:	[mm]	--	40	50	70	--	90	135

Installation process

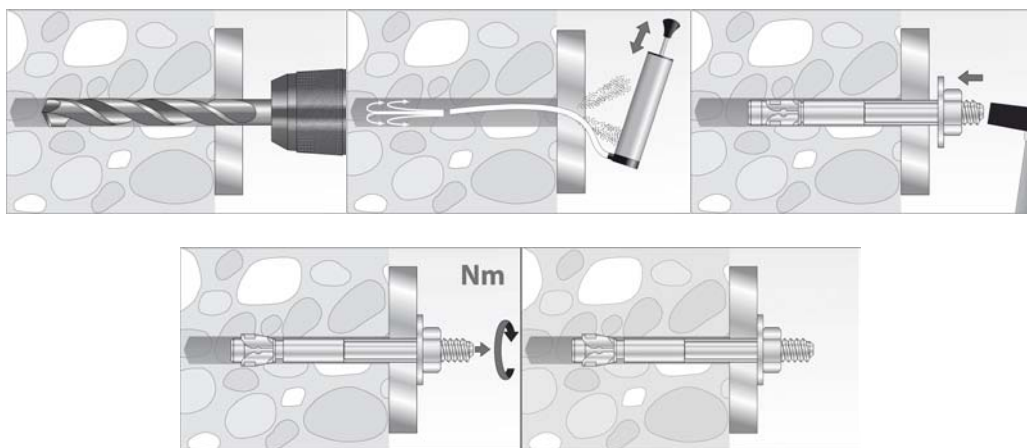

S-Fix Plus / Slim Fix anchor	Annex C1
Performances	
Installation parameters and installation procedure.	

English translation prepared by IETcc

Table C2: Characteristic resistance values to tension loads of design method A according to EN 1992-4 for S-Fix Plus / Slim Fix anchor

S-Fix Plus / Slim Fix: GALVANISED ANCHOR			Performances						
			M6	M8	M10	M12	M14	M16	M20
STEEL FAILURE									
$N_{Rk,s}$	Characteristic resistance:	[kN]	7.4	13.0	23.7	33.3	49.1	60.1	99.5
$\gamma_{M,s}$	Partial safety factor:	[-]	1.40	1.40	1.40	1.40	1.40	1.40	1.40
PULL OUT FAILURE									
Standard embedment depth									
$N_{Rk,p}$	Characteristic resistance in C20/25 uncracked concrete:	[kN]	-- ¹⁾	-- ¹⁾	19.0	-- ¹⁾	-- ¹⁾	-- ¹⁾	-- ¹⁾
γ_{ins}	Installation safety factor:	[-]	1.0						
Ψ_c	Increasing factors for $N_{Rk,p}^0$:	C30/37	1.22				1.22		
		C40/50	1.41				1.41		
		C50/60	1.58				1.58		
Reduced embedment depth									
$N_{Rk,p}$	Characteristic resistance in C20/25 uncracked concrete:	[kN]	--	10	-- ¹⁾	-- ¹⁾	--	-- ¹⁾	-- ¹⁾
γ_{ins}	Installation safety factor:	[-]	--	1.0			--	1.0	
Ψ_c	Increasing factors for $N_{Rk,p}^0$:	C30/37	--	1.22			--	1.22	
		C40/50	--	1.41			--	1.41	
		C50/60	--	1.58			--	1.58	
CONCRETE CONE FAILURE AND SPLITTING FAILURE									
Standard embedment depth									
$h_{ef, std}$	Effective anchorage depth:	[mm]	40	48	55	65	75	84	103
$k_{ucr, N}$	Factor for uncracked concrete:	[-]	11.0						
γ_{ins}	Installation safety factor:	[-]	1.0						
$s_{cr, N}$	Concrete cone failure:	[mm]	3 x h_{ef}						
$c_{cr, N}$		[mm]	1.5 x h_{ef}						
$s_{cr, sp}$	Splitting failure:	[mm]	160	192	220	260	300	280	360
$c_{cr, sp}$		[mm]	80	96	110	130	150	140	180
Reduced embedment depth									
$h_{ef, std}$	Effective anchorage depth:	[mm]	--	35	42	50	--	65	75
$k_{ucr, N}$	Factor for uncracked concrete:	[-]	--	11.0			--	11.0	
γ_{ins}	Installation safety factor:	[-]	--	1.0			--	1.0	
$s_{cr, N}$	Concrete cone failure	[mm]	--	3 x h_{ef}			--	3 x h_{ef}	
$c_{cr, N}$		[mm]	--	1.5 x h_{ef}			--	1.5 x h_{ef}	
$s_{cr, sp}$	Splitting failure:	[mm]	--	140	168	200	--	260	300
$c_{cr, sp}$		[mm]	--	70	84	100	--	130	150

¹⁾ Pull out failure is not decisive

S-Fix Plus / Slim Fix anchor

Performances

Characteristic values for tension loads.

Annex C2

Table C3: Characteristic resistance values to shear loads of design method A according to EN 1992-4 for S-Fix Plus / Slim Fix anchor

S-Fix Plus / Slim Fix: GALVANISED ANCHOR		Performances								
		M6	M8	M10	M12	M14	M16	M20		
STEEL FAILURE WITHOUT LEVER ARM										
$V_{Rk,s}$	Characteristic resistance:	[kN]	5.1	9.3	14.7	20.6	28.1	38.4	56.3	
k_7	Ductility factor:	[-]	1.0							
$\gamma_{M,s}$	Partial safety factor:	[-]	1.25							
STEEL FAILURE WITH LEVER ARM										
$M_{Rk,s}^0$	Characteristic bending moment:	[Nm]	7.7	19.1	38.1	64.1	102.2	163.1	298.5	
$\gamma_{M,s}$	Partial safety factor:	[-]	1.25							
CONCRETE PRYOUT FAILURE										
k_8	k factor:	for $h_{ef, std}$	[-]	1.0	1.0	1.0	2.0	2.0	2.0	2.0
		for $h_{ef, red}$	[-]	--	1.0	1.0	1.0	--	2.0	2.0
γ_{ins}	Installation safety factor:	[-]	1.0							
CONCRETE EDGE FAILURE										
l_f	Effective length of anchor:	for $h_{ef, std}$	[mm]	40	48	55	65	75	84	103
		for $h_{ef, red}$	[mm]	--	35	42	50	--	65	75
d_{nom}	Outside diameter of anchor:	[mm]	6	8	10	12	14	16	20	
γ_{ins}	Installation safety factor:	[-]	1.0							

Table C4: Displacements under tension loads for S-Fix Plus / Slim Fix

S-Fix Plus / Slim Fix: GALVANISED ANCHOR		Performances							
		M6	M8	M10	M12	M14	M16	M20	
Standard embedment depth									
	Tension load in non cracked concrete:	[kN]	3.8	6.6	9.0	12.6	15.6	18.5	25.1
$\bar{\delta}_{N0}$	Displacement:	[mm]	0.4	0.7	1.0	1.2	1.3	1.9	2.2
$\bar{\delta}_{N\infty}$		[mm]	1.8	2.1	2.4	2.6	2.7	3.3	3.8
Reduced embedment depth									
	Tension load in non cracked concrete:	[kN]	--	4.8	6.5	8.5	--	12.6	15.6
$\bar{\delta}_{N0}$	Displacement:	[mm]	--	0.3	0.6	1.0	--	1.6	1.9
$\bar{\delta}_{N\infty}$		[mm]	--	1.4	1.7	2.1	--	2.7	3.0

Table C5: Displacements under shear loads for S-Fix Plus / Slim Fix

S-Fix Plus / Slim Fix: GALVANISED ANCHOR		Performances							
		M6	M8	M10	M12	M14	M16	M20	
Standard embedment depth									
	Shear load in non cracked concrete:	[kN]	2.9	5.3	8.4	11.8	16.0	21.9	32.1
$\bar{\delta}_{V0}$	Displacement:	[mm]	0.65	2.80	1.75	2.45	2.78	3.53	4.13
$\bar{\delta}_{V\infty}$		[mm]	0.98	4.20	2.63	3.68	4.16	5.29	6.19
Reduced embedment depth									
	Shear load in non cracked concrete:	[kN]	--	5.3	8.4	11.8	--	21.9	32.1
$\bar{\delta}_{V0}$	Displacement:	[mm]	--	0.59	1.22	1.10	--	3.10	3.40
$\bar{\delta}_{V\infty}$		[mm]	--	0.89	1.83	1.65	--	4.60	5.10

S-Fix Plus / Slim Fix anchor	Annex C3
Performances	
Characteristic values for shear loads. Displacements under tension and shear loads.	

Table D1: Installation parameters for S-Fix Plus A2, S-Fix Plus A4 anchor

S-Fix Plus A2, S-Fix Plus A4: STAINLESS STEEL ANCHOR Installation parameters		Performances					
		M6	M8	M10	M12	M16	M20
d_0	Nominal diameter of drill bit: [mm]	6	8	10	12	16	20
d_f	Fixture clearance hole diameter: [mm]	7	9	12	14	18	22
T_{inst}	Nominal installation torque: [Nm]	7	20	35	60	120	240
Standard embedment depth							
L_{min}	Minimum length of the bolt: [mm]	60	75	85	100	125	160
h_{min}	Minimum thickness of concrete member: [mm]	100	100	110	130	168	206
h_1	Depth of drilled hole \geq [mm]	55	65	75	85	110	135
h_{nom}	Overall anchor embed depth in concrete: [mm]	49.5	59.5	66.5	77	103.5	125
$h_{ef, std}$	Effective anchorage depth: [mm]	40	48	55	65	84	103
t_{fix}	Thickness of fixture for DIN 125 washer \leq [mm]	L-58	L-70	L-80	L-92	L-122	L-147
t_{fix}	Thickness of fixture for DIN 9021 or DIN 440 washer \leq [mm]	L-58	L-71	L-80	L-94	L-124	L-149
s_{min}	Minimum allowable spacing: [mm]	50	65	70	85	110	135
c_{min}	Minimum allowable distance: [mm]	50	65	70	85	110	135
Reduced embedment depth							
L_{min}	Minimum length of the bolt: [mm]	--	60	70	80	--	--
h_{min}	Minimum thickness of concrete member: [mm]	--	100	100	100	--	--
h_1	Depth of drilled hole: [mm]	--	50	60	70	--	--
h_{nom}	Overall anchor embed depth in concrete: [mm]	--	46.5	53.5	62	--	--
$h_{ef, red}$	Effective anchorage depth: [mm]	--	35	42	50	--	--
t_{fix}	Thickness of fixture for DIN 125 washer \leq [mm]	--	L-57	L-67	L-77	--	--
t_{fix}	Thickness of fixture for DIN 9021 or DIN 440 washer \leq [mm]	--	L-58	L-67	L-79	--	--
s_{min}	Minimum allowable spacing: [mm]	--	65	70	85	--	--
c_{min}	Minimum allowable distance: [mm]	--	65	70	85	--	--

Installation process

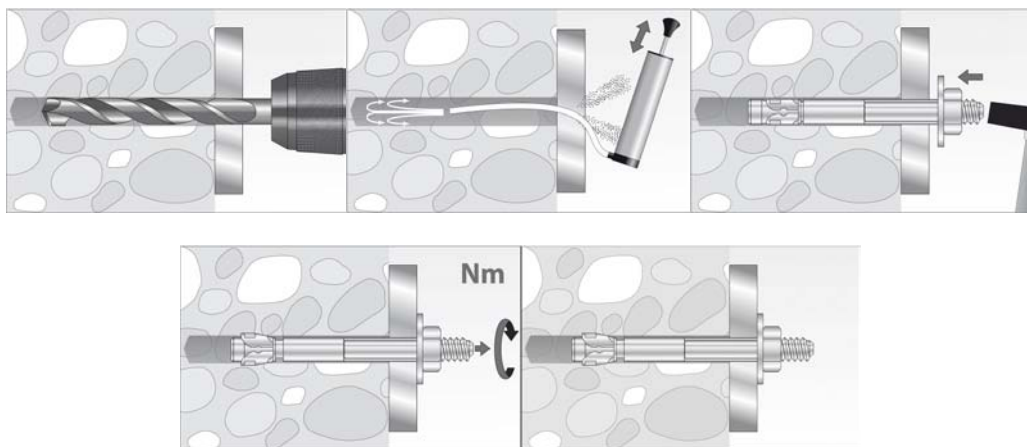

S-Fix Plus A2, S-Fix Plus A4 anchor

Performances

Installation parameters and installation procedure.

Annex D1

English translation prepared by IETcc

Table D2: Characteristic resistance values to tension loads of design method A according to EN 1992-4 for S-Fix Plus A2, S-Fix Plus A4 anchor

S-Fix Plus A2, S-Fix Plus A4: STAINLESS STEEL ANCHOR		Performances						
		M6	M8	M10	M12	M16	M20	
STEEL FAILURE								
$N_{Rk,s}$	Characteristic resistance:	[kN]	10.1	19.1	34.3	49.6	85.9	140.7
$\gamma_{M,s}$	Partial safety factor:	[-]	1.68					
PULL OUT FAILURE								
Standard embedment depth								
$N_{Rk,p}$	Characteristic resistance in C20/25 uncracked concrete:	[kN]	-- ¹⁾	12	16	25	35	50
γ_{ins}	Installation safety factor:	[-]	--	1.0	1.2			
Reduced embedment depth								
$N_{Rk,p}$	Characteristic resistance in C20/25 uncracked concrete:	[kN]	--	9	12	16	--	--
γ_{ins}	Installation safety factor:	[-]	--	1.2			--	--
Ψ_c	Increasing factors for $N_{Rk,p}^0$:	C30/37	1.22					
		C40/50	1.41					
		C50/60	1.58					
CONCRETE CONE FAILURE AND SPLITTING FAILURE								
Standard embedment depth								
$h_{ef, std}$	Effective anchorage depth:	[mm]	40	48	55	65	84	103
$k_{Ucr,N}$	Factor for uncracked concrete:	[-]	11.0					
γ_{ins}	Installation safety factor:	[-]	1.0		1.2			
$s_{Cr,N}$	Concrete cone failure:	[mm]	3 x h_{ef}					
$c_{Cr,N}$		[mm]	1.5 x h_{ef}					
$s_{Cr,sp}$	Splitting failure:	[mm]	160	192	220	260	336	412
$c_{Cr,sp}$		[mm]	80	96	110	130	168	206
Reduced embedment depth								
$h_{ef, std}$	Effective anchorage depth:	[mm]	--	35	42	50	--	--
$k_{Ucr,N}$	Factor for uncracked concrete:	[-]	11.0					
γ_{ins}	Installation safety factor:	[-]	--	1.2			--	--
$s_{Cr,N}$	Concrete cone failure:	[mm]	--	3 x h_{ef}			--	--
$c_{Cr,N}$		[mm]	--	1.5 x h_{ef}			--	--
$s_{Cr,sp}$	Splitting failure:	[mm]	--	140	168	200	--	--
$c_{Cr,sp}$		[mm]	--	70	84	100	--	-

¹⁾ Pull out failure is not decisive

S-Fix Plus A2, S-Fix Plus A4 anchor	Annex D2
Performances	
Characteristic values for tension loads.	

Table D3: Characteristic resistance values to shear loads of design method A according to EN 1992-4 for S-Fix Plus A2, S-Fix Plus A4 anchor

S-Fix Plus A2, S-Fix Plus A4: STAINLESS STEEL ANCHOR				Performances					
				M6	M8	M10	M12	M16	M20
STEEL FAILURE WITHOUT LEVER ARM									
$V_{Rk,s}$	Characteristic resistance:	[kN]	6.0	10.9	17.4	25.2	47.1	73.5	
k_7	Ductility factor:	[-]	1.0						
$\gamma_{M,s}$	Partial safety factor	[-]	1.52						
STEEL FAILURE WITH LEVER ARM									
$M_{Rk,s}^0$	Characteristic bending moment:	[Nm]	9.2	22.5	44.9	78.6	200	389	
$\gamma_{M,s}$	Partial safety factor:	[-]	1.52						
CONCRETE PRYOUT FAILURE									
k_8	k factor:	for $h_{ef, std}$	[-]	1.0	1.0	1.0	2.0	2.0	2.0
		for $h_{ef, red}$	[-]	--	1.0	1.0	1.0	--	--
γ_{ins}	Installation safety factor:	[-]	1.0						
CONCRETE EDGE FAILURE									
l_f	Effective length of anchor under shear loads:	for $h_{ef, std}$	[mm]	40	48	55	65	84	103
		for $h_{ef, red}$	[mm]	--	35	42	50	--	--
d_{nom}	Outside diameter of anchor:	[mm]	6	8	10	12	16	20	
γ_{ins}	Installation safety factor:	[-]	1.0						

Table D4: Displacements under tension loads for S-Fix Plus A2, S-Fix Plus A4

S-Fix Plus A2, S-Fix Plus A4: STAINLESS STEEL ANCHOR				Performances					
				M6	M8	M10	M12	M16	M20
Standard embedment depth									
Tension load in non cracked concrete:		[kN]	4.3	5.7	6.3	9.9	13.8	19.8	
δ_{N0}	Displacement:	[mm]	0.42	0.22	0.17	0.19	0.19	0.11	
$\delta_{N\infty}$		[mm]	1.33	1.33	1.33	1.33	1.33	1.33	
Reduced embedment depth									
Tension load in non cracked concrete:		[kN]	--	4.2	5.7	7.6	--	--	
δ_{N0}	Displacement:	[mm]	--	0.07	0.04	0.32	--	--	
$\delta_{N\infty}$		[mm]	--	0.60	0.60	0.60	--	--	

Table D5: Displacements under shear loads for S-Fix Plus A2, S-Fix Plus A4

S-Fix Plus A2, S-Fix Plus A4: STAINLESS STEEL ANCHOR				Performances					
				M6	M8	M10	M12	M16	M20
Standard embedment depth									
Shear load in non cracked concrete:		[kN]	2.8	5.1	8.1	11.8	22.1	34.5	
δ_{V0}	Displacement:	[mm]	1.66	1.79	3.83	4.13	5.75	6.59	
$\delta_{V\infty}$		[mm]	2.49	2.68	5.74	6.19	8.62	9.88	
Reduced embedment depth									
Shear load in non cracked concrete:		[kN]	--	5.1	8.1	11.8	--	--	
δ_{V0}	Displacement:	[mm]	--	0.60	3.83	4.13	--	--	
$\delta_{V\infty}$		[mm]	--	0.90	5.74	6.19	--	--	

S-Fix Plus A2, S-Fix Plus A4 anchor

Performances

Characteristic values for shear loads.
Displacements under tension and shears.

Annex D3