

Approval body for construction products
and types of construction

Bautechnisches Prüfamt

An institution established by the Federal and
Laender Governments



European Technical Assessment

ETA-05/0067
of 27 March 2018

English translation prepared by DIBt - Original version in German language

General Part

Technical Assessment Body issuing the
European Technical Assessment:

Deutsches Institut für Bautechnik

Trade name of the construction product

TOX Highload Anchor SZ

Product family
to which the construction product belongs

Mechanical anchor for use in concrete

Manufacturer

TOX-Dübel-Technik GmbH
Brunnenstraße 31
72505 Krauchenwies-Ablach
DEUTSCHLAND

Manufacturing plant

TOX Herstellwerk 10, Deutschland

This European Technical Assessment
contains

20 pages including 3 annexes which form an integral part
of this assessment

This European Technical Assessment is
issued in accordance with Regulation (EU)
No 305/2011, on the basis of

EAD 330232-00-0601

European Technical Assessment

ETA-05/0067

English translation prepared by DIBt

Page 2 of 20 | 27 March 2018

The European Technical Assessment is issued by the Technical Assessment Body in its official language. Translations of this European Technical Assessment in other languages shall fully correspond to the original issued document and shall be identified as such.

Communication of this European Technical Assessment, including transmission by electronic means, shall be in full. However, partial reproduction may only be made with the written consent of the issuing Technical Assessment Body. Any partial reproduction shall be identified as such.

This European Technical Assessment may be withdrawn by the issuing Technical Assessment Body, in particular pursuant to information by the Commission in accordance with Article 25(3) of Regulation (EU) No 305/2011.

Specific Part

1 Technical description of the product

The TOX Highload Anchor SZ is an anchor made of galvanised steel or made of stainless steel which is placed into a drilled hole and anchored by torque-controlled expansion. The following anchor types are covered:

- Anchor type SZ-B with threaded bolt,
- Anchor type SZ-S with hexagon head screw,
- Anchor type SZ-SK with countersunk washer and countersunk screw.

The product description is given in Annex A.

2 Specification of the intended use in accordance with the applicable European Assessment Document

The performances given in Section 3 are only valid if the anchor is used in compliance with the specifications and conditions given in Annex B.

The verifications and assessment methods on which this European Technical Assessment is based lead to the assumption of a working life of the anchor of at least 50 years. The indications given on the working life cannot be interpreted as a guarantee given by the producer, but are to be regarded only as a means for choosing the right products in relation to the expected economically reasonable working life of the works.

3 Performance of the product and references to the methods used for its assessment

3.1 Mechanical resistance and stability (BWR 1)

Essential characteristic	Performance
Characteristic resistance for static and quasi-static loading	See Annex C1 to C5
Characteristic resistance for seismic performance category C1 and C2	See Annex C6 to C7
Displacements under tension and shear loads	See Annex C9 and C10

3.2 Safety in case of fire (BWR 2)

Essential characteristic	Performance
Reaction to fire	Anchorage satisfy requirements for Class A1
Resistance to fire	See Annex C8

English translation prepared by DIBt

4 Assessment and verification of constancy of performance (AVCP) system applied, with reference to its legal base

In accordance with the European Assessment Document EAD 330232-00-0601 the applicable European legal act is: [96/582/EC].

The system to be applied is: 1

5 Technical details necessary for the implementation of the AVCP system, as provided for in the applicable European Assessment Document

Technical details necessary for the implementation of the AVCP system are laid down in the control plan deposited with Deutsches Institut für Bautechnik.

Issued in Berlin on 27 March 2018 by Deutsches Institut für Bautechnik

BD Dipl.-Ing. Andreas Kummerow
Head of Department

beglaubigt:
Baderschneider

TOX Highload Anchor SZ

Anchor type SZ-B with threaded bolt

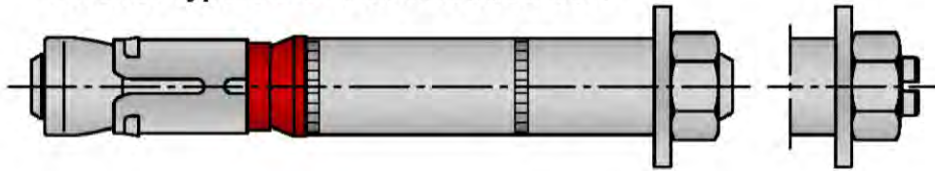

SZ-B (M6-M24)
SZ-B (M8-M16) A4

Anchor type SZ-S with hexagon head screw

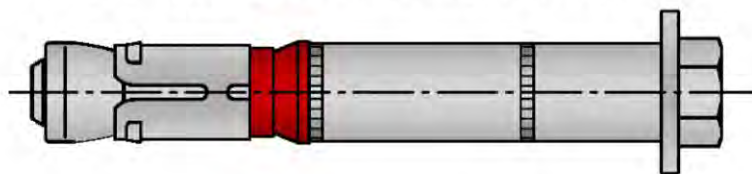

SZ-S (M6-M24)
SZ-S (M8-M16) A4

Anchor type SZ-SK with countersunk washer and countersunk screw

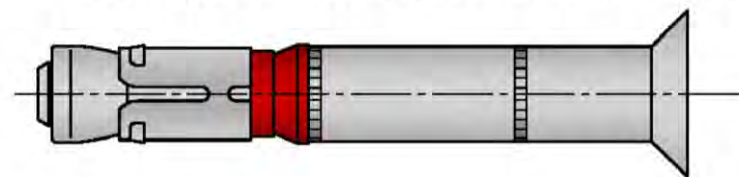

SZ-SK (M6-M12)
SZ-SK (M8-M12) A4

Installation condition

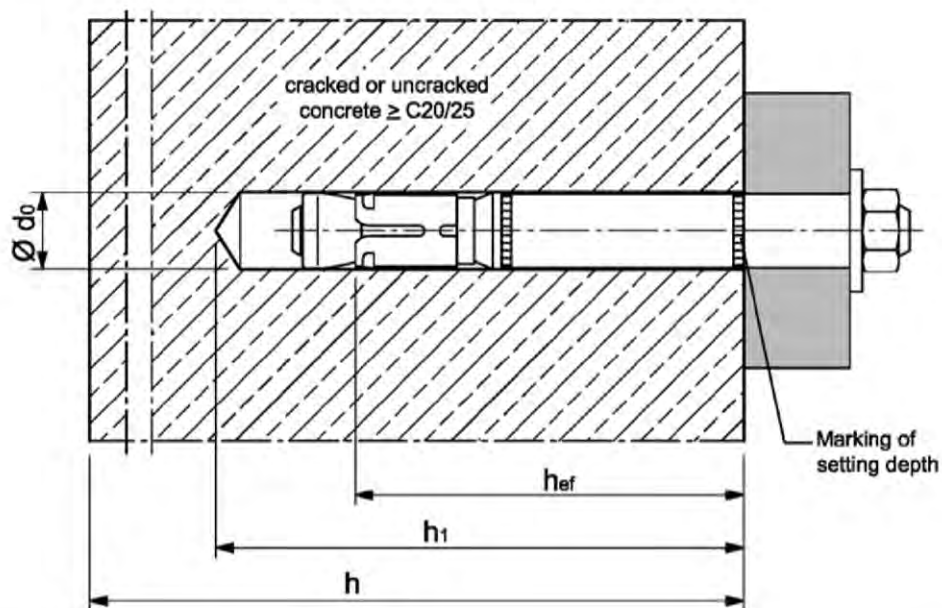

TOX Highload Anchor SZ

Product description
Product and installation situation

Annex A1

SZ-B

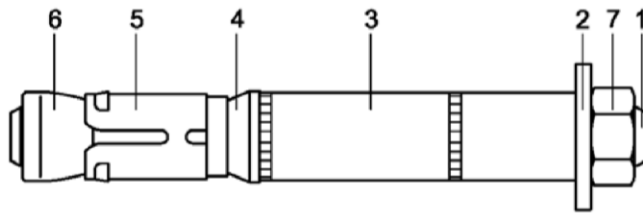

SZ-S

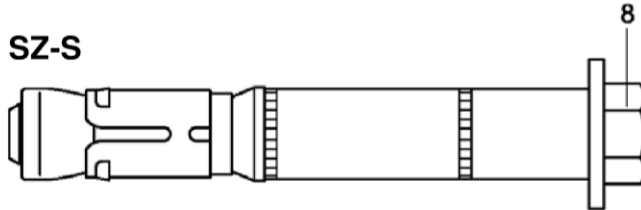

SZ-SK

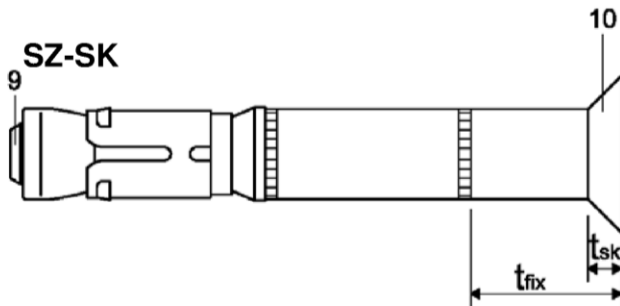

Marking:

expansion sleeve:

- Identifying mark of manufacturing plant ◇
- additional marking of stainless steel A4 A4
- Anchor identity (alternatively on distance sleeve) SZ
- size of thread (alternatively M10 on distance sleeve)

Distance sleeve:

- Diameter 15
- max. thickness of fixture 25
- additional marking for countersunk version SK

marking on the washer of anchor size SZ 24/M16L L

Table A1: Designation of anchor parts and materials

Part	Designation	Materials galvanised $\geq 5 \mu\text{m}$, acc. to EN ISO 4042:1999	Stainless steel A4
1	Threaded bolt	Steel, Strength class 8.8, EN ISO 898-1:2013	Stainless steel, 1.4401, 1.4404 or 1.4571, EN 10088:2014
2	Washer	Steel, EN 10139:2016	Stainless steel, EN 10088:2014
3	Distance sleeve	Steel tube EN 10305-2:2016, EN 10305-3:2016;	Steel tube stainless steel, 1.4401, 1.4404 or 1.4571; EN 10217-7:2014, EN 10216-5:2013
4	Ring	Polyethylene	Polyethylene
5	Expansion sleeve	Steel, EN 10139:2016	Stainless steel, 1.4401, 1.4404 or 1.4571, EN 10088:2014
6	Threaded cone	Steel EN 10083-2:2006	Stainless steel, 1.4401, 1.4404 or 1.4571, EN 10088:2014
7	Hexagon nut	Steel, Strength class 8, EN ISO 898-2:2012	Stainless steel, strength class 70, EN ISO 3506-2:2009
8	Hexagon head screw	Steel, Strength class 8.8, EN ISO 898-1:2013	Stainless steel, strength class 70, EN ISO 3506-1:2009
9	Countersunk screw	Steel, Strength class 8.8, EN ISO 898-1:2013	Stainless steel, strength class 70, EN ISO 3506-1:2009
10	Countersunk washer	Steel, EN 10083-2:2006	Stainless steel, 1.4401, 1.4404 or 1.4571, EN 10088:2014, zinc plated

TOX Highload Anchor SZ

Product description
Marking and materials

Annex A2

Specification of intended use

TOX Highload Anchor SZ, steel zinc plated	10/M6	12/M8	15/M10	18/M12	24/M16	24/ M16L	28/M20	32/M24
Static or quasi-static action	✓							
Seismic action (SZ-B and SZ-S)	-	C1 + C2						
Seismic action (SZ-SK)	-	C1 + C2				-		
Fire exposure	R 30 ... R 120							
TOX Highload Anchor SZ, stainless steel A4	12/M8	15/M10	18/M12	24/M16				
Static or quasi-static action	✓							
Seismic action (SZ-B and SZ-S)	C1 + C2							
Seismic action (SZ-SK)	C1 + C2			-				
Fire exposure	R30 ... R120							

Base materials:

- Cracked and uncracked concrete
- Reinforced or unreinforced normal weight concrete according to EN 206-1:2000
- Strength classes C20/25 to C50/60 according to EN 206-1:2000

Use conditions (Environmental conditions):

- Structures subject to dry internal conditions (zinc plated steel or stainless steel).
- Structures subject to external atmospheric exposure (including industrial and marine environment) and to permanently damp internal conditions, if no particular aggressive conditions exist (stainless steel).

Note: Particular aggressive conditions are e.g. permanent, alternating immersion in seawater or the splash zone of seawater, chloride atmosphere of indoor pools or atmosphere with extreme chemical pollution (e.g. in desulphurization plants or road tunnels where de-icing materials are used.)

Design:

- Anchorages are designed under the responsibility of an engineer experienced in anchorages and concrete work.
- Verifiable calculation notes and drawings are prepared taking account of the loads to be anchored. The position of the anchor is indicated on the design drawings (e.g. position of the anchor relative to reinforcement or to supports, etc.).
- Anchorages under static or quasi-static actions, seismic actions and under fire exposure are designed in accordance with FprEN 1992-4:2016 and TR 055.

Installation:

- Anchor installation carried out by appropriately qualified personnel and under the supervision of the person responsible for technical matters on site.
- In case of aborted hole: new drilling at a minimum distance away of twice the depth of the aborted hole or smaller distance if the aborted drill hole is filled with high strength mortar and if under shear or oblique tension load it is not in the direction of load application.
- Anchor installation such that the effective anchorage depth is complied with. This compliance is ensured when the embedment mark of the anchor does no more exceed the concrete surface.
- Use as supplied by the manufacturer without replacing individual parts.
- Drilling of hole only by hammer drilling (use of vacuum drill bits is admissible)

TOX Highload Anchor SZ

Intended use
Specification of intended use

Annex B1

Installation instructions

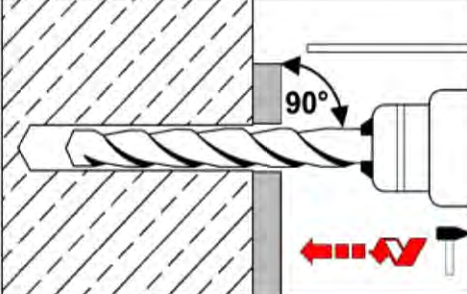
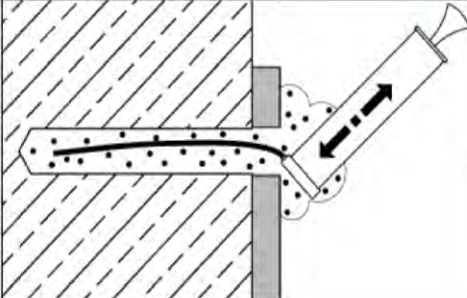
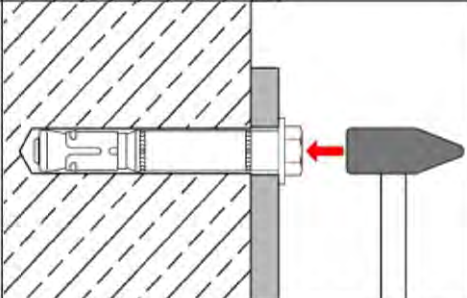
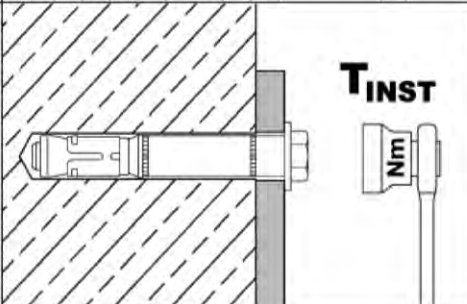
1		<p>Drill hole perpendicular to concrete surface. If using a vacuum drill bit, proceed with step 3.</p>
2		<p>Blow out dust. Alternatively vacuum clean down to the bottom of the hole.</p>
3		<p>Drive in anchor.</p>
4		<p>Apply installation torque T_{inst} by using calibrated torque wrench.</p>

TOX Highload Anchor SZ

Intended use
Installation instructions

Annex B2

Table B1: Installation parameters, steel zinc plated

Anchor size		10/M6	12/M8	15/M10	18/M12	24/M16	24/M16L	28/M20	32/M24
Size of thread	[-]	M6	M8	M10	M12	M16	M16	M20	M24
Effective anchorage depth	h_{ef} [mm]	50	60	71	80	100	115	125	150
Nominal diameter of drill bit	$d_0 =$ [mm]	10	12	15	18	24	24	28	32
Cutting diameter of drill bit	$d_{cut} \leq$ [mm]	10,45	12,5	15,5	18,5	24,55	24,55	28,55	32,7
Depth of drill hole	$h_1 \geq$ [mm]	65	80	95	105	130	145	160	180
Diameter of clearance hole in the fixture	$d_f \leq$ [mm]	12	14	17	20	26	26	31	35
Thickness of countersunk washer SZ-SK	t_{sk} [mm]	4	5	6	7	-	-	-	-
Minimum thickness of fixture SZ-SK	$t_{fix \min}^{2)}$ [mm]	8	10	14	18	-	-	-	-
Installation torque	T_{inst} (SZ-B, SZ-S) [Nm]	15	30	50	80	160	160	280	280
	T_{inst} (SZ-SK) [Nm]	10	25	55	70	-	-	-	-
Minimum thickness of member	h_{min} [mm]	100	120	140	160	200	230	250	300
Minimum spacing ^{1) 3)} cracked concrete	s_{min} [mm]	50	50	60	70	100	100	125	150
	for $c \geq$ [mm]	50	80	120	140	180	180	300	300
Minimum edge distance ^{1) 3)} cracked concrete	c_{min} [mm]	50	55	60	70	100	100	180	150
	for $s \geq$ [mm]	50	100	120	160	220	220	540	300
Minimum spacing ^{1) 3)} uncracked concrete	s_{min} [mm]	50	60	60	70	100	100	125	150
	for $c \geq$ [mm]	80	100	120	140	180	180	300	300
Minimum edge distance ^{1) 3)} uncracked concrete	c_{min} [mm]	50	60	60	70	100	100	180	150
	for $s \geq$ [mm]	100	120	120	160	220	220	540	300

¹⁾ Intermediate values by linear interpolation

²⁾ Depending on the existing shear load, the thickness of the fixture may be reduced to the thickness of the countersunk washer t_{sk} (see Annex A2). It must be verified that the present shear load can be transferred completely into the distance sleeve (bearing of hole).

³⁾ For fire exposure from more than one side $c \geq 300$ mm or $c_{min} \geq 300$ mm applies.

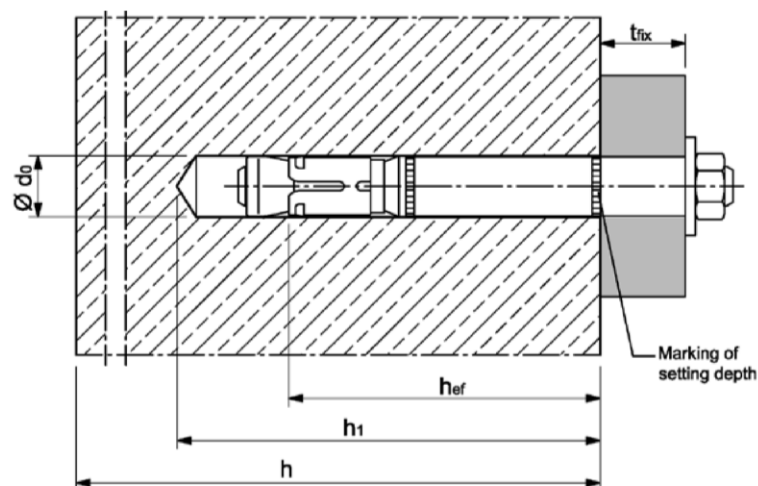

TOX Highload Anchor SZ

Intended use
Installation parameters, steel zinc plated

Annex B3

Table B2: Installation parameters, stainless steel A4

Anchor size		12/M8	15/M10	18/M12	24/M16
Size of thread	[-]	M8	M10	M12	M16
Effective anchorage depth	h_{ef} [mm]	60	71	80	100
Nominal diameter of drill bit	$d_0 =$ [mm]	12	15	18	24
Cutting diameter of drill bit	$d_{cut} \leq$ [mm]	12,5	15,5	18,5	24,55
Depth of drill hole	$h_1 \geq$ [mm]	80	95	105	130
Diameter of clearance hole in the fixture	$d_f \leq$ [mm]	14	17	20	26
Thickness of countersunk washer SZ-SK	t_{sk} [mm]	5	6	7	-
Minimum thickness of fixture SZ-SK	$t_{fix\ min}^{2)}$ [mm]	10	14	18	-
Installation torque	T_{inst} (SZ-B) [Nm]	35	55	90	170
	T_{inst} (SZ-S) [Nm]	30	50	80	170
	T_{inst} (SZ-SK) [Nm]	17,5	42,5	50	-
Minimum thickness of member	h_{min} [mm]	120	140	160	200
Minimum spacing ^{1) 3)} cracked concrete	s_{min} [mm]	50	60	70	80
	for $c \geq$ [mm]	80	120	140	180
Minimum edge distance ^{1) 3)} cracked concrete	c_{min} [mm]	50	60	70	80
	for $s \geq$ [mm]	80	120	160	200
Minimum spacing ^{1) 3)} uncracked concrete	s_{min} [mm]	50	60	70	80
	for $c \geq$ [mm]	80	120	140	180
Minimum edge distance ^{1) 3)} uncracked concrete	c_{min} [mm]	50	85	70	180
	for $s \geq$ [mm]	80	185	160	80

¹⁾ Intermediate values by linear interpolation

²⁾ Depending on the existing shear load, the thickness of the fixture may be reduced to the thickness of the countersunk washer t_{sk} (see Annex A2). It must be verified that the present shear load can be transferred completely into the distance sleeve (bearing of hole).

³⁾ For fire exposure from more than one side $c \geq 300$ mm or $c_{min} \geq 300$ mm applies.

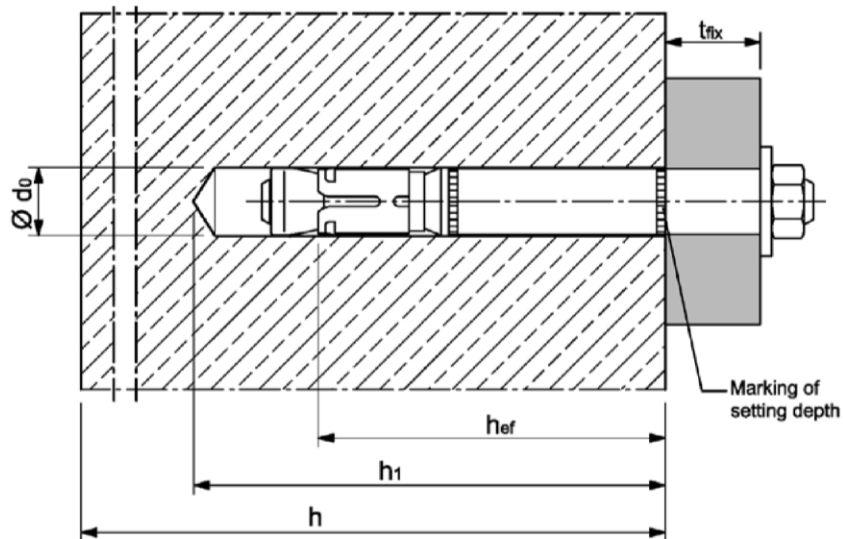

TOX Highload Anchor SZ

Intended use
Installation parameters, stainless steel A4

Annex B4

Table C1: Characteristic values for **tension load, cracked concrete,** static or quasi-static action, **steel zinc plated**

Anchor size			10/M6	12/M8	15/M10	18/M12	24/M16	24/ M16L	28/M20	32/M24
Installation safety factor	γ_{inst}	[-]	1,0							
Steel failure										
Characteristic resistance	$N_{Rk,s}$	[kN]	16	29	46	67	126	126	196	282
Partial safety factor	γ_{Ms}	[-]	1,5							
Pull-out failure										
Characteristic resistance in cracked concrete C20/25	$N_{Rk,p}$	[kN]	5	12	16	1)	1)	1)	1)	1)
Increasing factor for $N_{Rk,p}$	ψ_C	[-]	$\left(\frac{f_{ck}}{20}\right)^{0,5}$							
Concrete cone failure										
Effective anchorage depth	h_{ef}	[mm]	50	60	71	80	100	115	125	150
Factor $k_1 =$	$k_{cr,N}$	[-]	7,7							

¹⁾ Pull-out is not decisive

Table C2: Characteristic values for **tension load, cracked concrete,** static or quasi-static action, **stainless steel A4**

Anchor size			12/M8	15/M10	18/M12	24/M16
Installation safety factor	γ_{inst}	[-]	1,0			
Steel failure						
SZ-B						
Characteristic resistance	$N_{Rk,s}$	[kN]	26	41	60	110
Partial safety factor	γ_{Ms}	[-]	1,5			
SZ-S and SZ-SK						
Characteristic resistance	$N_{Rk,s}$	[kN]	26	41	60	110
Partial safety factor	γ_{Ms}	[-]	1,87			
Pull-out failure						
Characteristic resistance in cracked concrete C20/25	$N_{Rk,p}$	[kN]	9	16	1)	1)
Increasing factor for $N_{Rk,p}$	ψ_C	[-]	$\left(\frac{f_{ck}}{20}\right)^{0,5}$			
Concrete cone failure						
Effective anchorage depth	h_{ef}	[mm]	60	71	80	100
Factor $k_1 =$	$k_{cr,N}$	[-]	7,7			

¹⁾ Pull-out is not decisive

TOX Highload Anchor SZ

Performance

Characteristic values for **tension load, cracked concrete,** static or quasi-static action

Annex C1

Table C3: Characteristic values for **tension load, uncracked concrete,** static or quasi-static action, **steel zinc plated**

Anchor size			10/M6	12/M8	15/M10	18/M12	24/M16	24/ M16L	28/M20	32/M24	
Installation safety factor	γ_{inst}	[-]	1,0								
Steel failure											
Characteristic resistance	$N_{Rk,s}$	[kN]	16	29	46	67	126	126	196	282	
Partial safety factor	γ_{Ms}	[-]	1,5								
Pull-out failure											
Characteristic resistance in uncracked concrete C20/25	$N_{Rk,p}$	[kN]	1)	20	1)	1)	1)	1)	1)	1)	
Increasing factor for $N_{Rk,p}$	ψ_C	[-]	$\left(\frac{f_{ck}}{20}\right)^{0,5}$								
Splitting failure (The higher resistance of case 1 and case 2 may be applied)											
Case 1											
Characteristic resistance in uncracked concrete C20/25	$N^0_{Rk,sp}$	[kN]	12	16	25	30	40	70	50	70	
Edge distance	$c_{cr,sp}$	[mm]	$1,5 h_{ef}$								
Increasing factor for $N^0_{Rk,sp}$	ψ_C	[-]	$\left(\frac{f_{ck}}{20}\right)^{0,5}$								
Case 2											
Characteristic resistance in uncracked concrete	$N^0_{Rk,sp}$	[kN]	$\min \{N_{Rk,p}; N^0_{Rk,c}\}$								
Edge distance	$c_{cr,sp}$	[mm]	$2,5 h_{ef}$				$1,5 h_{ef}$		$2,5 h_{ef}$	$2 h_{ef}$	
Concrete cone failure											
Effective Anchorage depth	h_{ef}	[mm]	50	60	71	80	100	115	125	150	
Edge distance	$c_{cr,N}$	[mm]	$1,5 h_{ef}$								
Factor $k_1 =$	$k_{Ucr,N}$	[-]	11,0								

¹⁾ Pull-out is not decisive

TOX Highload Anchor SZ

Performance

Characteristic values for **tension load, uncracked concrete,** static or quasi-static action, **steel zinc plated**

Annex C2

Table C4: Characteristic values for **tension load, uncracked concrete**, static or quasi-static action, **stainless steel A4**

Anchor size			12/M8	15/M10	18/M12	24/M16
Installation safety factor	γ_{inst}	[-]	1,0			
Steel failure						
SZ-B						
Characteristic resistance	$N_{Rk,s}$	[kN]	26	41	60	110
Partial safety factor	γ_{Ms}	[-]	1,5			
SZ-S and SZ-SK						
Characteristic resistance	$N_{Rk,s}$	[kN]	26	41	60	110
Partial safety factor	γ_{Ms}	[-]	1,87			
Pull-out failure						
Characteristic resistance in uncracked concrete C20/25	$N_{Rk,p}$	[kN]	16	25	35	1)
Increasing factor for $N_{Rk,p}$	ψ_C	[-]	$\left(\frac{f_{ck}}{20}\right)^{0,5}$			
Splitting failure						
Edge distance	$c_{Cr,sp}$	[mm]	180	235	265	300
Concrete cone failure						
Effective anchorage depth	h_{ef}	[mm]	60	71	80	100
Edge distance	$c_{Cr,N}$	[mm]	1,5 h_{ef}			
Factor $k_1 =$	$k_{UCr,N}$	[-]	11,0			

1) Pull-out is not decisive.

TOX Highload Anchor SZ

Performance

Characteristic values for **tension loads, uncracked concrete**, static or quasi-static action, **stainless steel A4**

Annex C3

Table C5: Characteristic values of **shear load**, static or quasi-static action, **steel zinc plated**

Anchor size			10/M6	12/M8	15/M10	18/M12	24/M16	24/ M16L	28/M20	32/M24
Steel failure without lever arm										
SZ-B										
Characteristic resistance	$V_{Rk,s}^0$	[kN]	16	25	36	63	91	91	122	200
Factor	k_7	[-]	1,0							
SZ-S and SZ-SK										
Characteristic resistance	$V_{Rk,s}^0$	[kN]	18	30	48	73	126	126	150	200
Factor	k_7	[-]	1,0							
Partial safety factor	γ_{Ms}	[-]	1,25							
Steel failure with lever arm										
Characteristic resistance	$M_{Rk,s}^0$	[Nm]	12	30	60	105	266	266	519	898
Partial safety factor	γ_{Ms}	[-]	1,25							
Concrete pry-out failure										
Factor	k_8	[-]	1,8	2,0						
Concrete edge failure										
Effective length of anchor in shear loading	l_f	[mm]	50	60	71	80	100	115	125	150
Outside diameter of anchor	d_{nom}	[mm]	10	12	15	18	24	24	28	32

TOX Highload Anchor SZ

Performance
Characteristic values for **shear load**, static or quasi-static action,
steel zinc plated

Annex C4

Table C6: Characteristic values for **shear load**, static or quasi-static action, **stainless steel A4**

Anchor size			12/M8	15/M10	18/M12	24/M16
Steel failure without lever arm						
Characteristic resistance	$V_{Rk,s}^0$ [kN]		24	37	62	92
SZ-B						
Factor	k_7 [-]		1,0			
Partial safety factor	γ_{Ms} [-]		1,25			
SZ-S						
Factor	k_7 [-]		1,0			
Partial safety factor	γ_{Ms} [-]		1,36			
SZ-SK						
Factor	k_7 [-]		0,8			-
Partial safety factor	γ_{Ms} [-]		1,36			-
Steel failure with lever arm						
Characteristic resistance	$M_{Rk,s}^0$ [Nm]		26	52	92	232
SZ-B						
Partial safety factor	γ_{Ms} [-]		1,25			
SZ-S and SZ-SK						
Partial safety factor	γ_{Ms} [-]		1,56			
Concrete pry-out failure						
Factor	k_8 [-]		2,0			
Concrete edge failure						
Effective length of anchor in shear loading	l_f [mm]		60	71	80	100
Outside diameter of anchor	d_{nom} [mm]		12	15	18	24

TOX Highload Anchor SZ

Performance
Characteristic values for **shear load**, static or quasi-static action,
stainless steel A4

Annex C5

Table C7: Characteristic values for **seismic action, Category C1 and C2, steel zinc plated**

Anchor size			12/M8	15/M10	18/M12	24/M16	24/M16L	28/M20	32/M24
Tension load									
Installation safety factor	γ_{inst}	[-]	1,0						
Steel failure									
Characteristic tension resistance category C1	$N_{Rk,s,eq,C1}$	[kN]	29	46	67	126	126	196	280
Characteristic tension resistance category C2	$N_{Rk,s,eq,C2}$	[kN]	29	46	67	126	126	196	280
Partial safety factor	γ_{Ms}	[-]	1,5						
Pull-out failure									
Characteristic tension resistance category C1	$N_{Rk,p,eq,C1}$	[kN]	12	16	25	36	44,4	50,3	63,3
Characteristic tension resistance category C2	$N_{Rk,p,eq,C2}$	[kN]	5,4	16,4	22,6	29,0	41,2	43,6	63,3
Shear load									
Steel failure without lever arm									
SZ-B									
Characteristic shear resistance category C1	$V_{Rk,s,eq,C1}$	[kN]	18,0	27,1	43,4	51,9	51,9	96,4	160,1
Characteristic shear resistance category C2	$V_{Rk,s,eq,C2}$	[kN]	12,7	20,5	31,5	50,1	50,1	67,1	108,1
SZ-S									
Characteristic shear resistance category C1	$V_{Rk,s,eq,C1}$	[kN]	18,0	27,1	43,4	51,9	51,9	96,4	160,1
Characteristic shear resistance category C2	$V_{Rk,s,eq,C2}$	[kN]	12,7	20,5	31,5	69,3	69,3	67,1	108,1
SZ-SK									
Characteristic shear resistance category C1	$V_{Rk,s,eq,C1}$	[kN]	25,2	36,5	50,4	-	-	-	-
Characteristic shear resistance category C2	$V_{Rk,s,eq,C2}$	[kN]	19,2	29,3	39,4	-	-	-	-
Partial safety factor	γ_{Ms}	[-]	1,25						

TOX Highload Anchor SZ

Performance
Characteristic values for **seismic action, steel zinc plated**

Annex C6

Table C8: Characteristic values for **seismic action, Category C1 and C2, stainless steel A4**

Anchor size			12/M8	15/M10	18/M12	24/M16
Tension load						
Installation safety factor	γ_{inst}	[-]	1,0			
Steel failure						
Characteristic tension resistance, category C1	$N_{Rk,s,eq,C1}$	[kN]	26	41	60	110
Characteristic tension resistance, category C2	$N_{Rk,s,eq,C2}$	[kN]	26	41	60	110
Partial safety factor SZ-B	γ_{Ms}	[-]	1,5			
Partial safety factor SZ-S and SZ-SK	γ_{Ms}	[-]	1,87			
Pull-out failure						
Characteristic tension resistance, category C1	$N_{Rk,p,eq,C1}$	[kN]	9	16	26	36
Characteristic tension resistance, category C2	$N_{Rk,p,eq,C2}$	[kN]	4,8	16,5	24,8	44,5
Shear load						
Steel failure without lever arm						
SZ-B						
Characteristic shear resistance, category C1	$V_{Rk,s,eq,C1}$	[kN]	9,6	13,3	25,4	75,4
Characteristic shear resistance, category C2	$V_{Rk,s,eq,C2}$	[kN]	9,7	14,0	18,0	32,2
Partial safety factor	γ_{Ms}	[-]	1,25			
SZ-S						
Characteristic shear resistance, category C1	$V_{Rk,s,eq,C1}$	[kN]	9,6	13,3	25,4	75,4
Characteristic shear resistance, category C2	$V_{Rk,s,eq,C2}$	[kN]	9,7	14,0	18,0	32,2
Partial safety factor	γ_{Ms}	[-]	1,36			
SZ-SK						
Characteristic shear resistance, category C1	$V_{Rk,s,eq,C1}$	[kN]	11,5	23,3	31,6	-
Characteristic shear resistance, category C2	$V_{Rk,s,eq,C2}$	[kN]	10,8	17,4	15,4	-
Partial safety factor	γ_{Ms}	[-]	1,36			

TOX Highload Anchor SZ

Performance
Characteristic values for **seismic action, stainless steel A4**

Annex C7

Table C9: Characteristic values under **fire exposure** in cracked and uncracked concrete C20/25 to C50/60

Anchor size		10/M6	12/M8	15/M10	18/M12	24/M16	24/ M16L	28/M20	32/M24
Tension load									
Steel failure									
Steel zinc plated									
Characteristic resistance	R30	$N_{RK,s,fi}$ [kN]	1,0	1,9	4,3	6,3	11,6	18,3	26,3
	R60		0,8	1,5	3,2	4,6	8,6	13,5	19,5
	R90		0,6	1,0	2,1	3,0	5,0	7,7	12,6
	R120		0,4	0,8	1,5	2,0	3,1	4,9	9,2
Stainless steel A4									
Characteristic resistance	R30	$N_{RK,s,fi}$ [kN]	-	6,1	10,2	15,7	29,2	-	-
	R60		-	4,4	7,3	11,1	20,6	-	-
	R90		-	2,6	4,3	6,4	12,0	-	-
	R120		-	1,8	2,8	4,1	7,7	-	-
Shear load									
Steel failure without lever arm									
Steel zinc plated									
Characteristic resistance	R30	$V_{RK,s,fi}$ [kN]	1,0	1,9	4,3	6,3	11,6	18,3	26,3
	R60		0,8	1,5	3,2	4,6	8,6	13,5	19,5
	R90		0,6	1,0	2,1	3,0	5,0	7,7	12,6
	R120		0,4	0,8	1,5	2,0	3,1	4,9	9,2
Stainless steel A4									
Characteristic resistance	R30	$V_{RK,s,fi}$ [kN]	-	14,3	22,7	32,8	61,0	-	-
	R60		-	11,1	17,6	25,5	47,5	-	-
	R90		-	7,9	12,6	18,3	34,0	-	-
	R120		-	6,3	10,0	14,6	27,2	-	-
Steel failure with lever arm									
Steel zinc plated									
Characteristic resistance	R30	$M^0_{RK,s,fi}$ [Nm]	0,8	2,0	5,6	9,7	24,8	42,4	83,6
	R60		0,6	1,5	4,1	7,2	18,3	29,8	61,9
	R90		0,4	1,0	2,7	4,7	11,9	17,1	40,1
	R120		0,3	0,8	1,9	3,1	6,6	10,7	29,2
Stainless steel A4									
Characteristic resistance	R30	$M^0_{RK,s,fi}$ [Nm]	-	6,2	13,2	24,4	61,8	-	-
	R60		-	4,5	9,4	17,2	43,6	-	-
	R90		-	2,7	5,6	10,0	25,3	-	-
	R120		-	1,8	3,6	6,4	16,2	-	-

If pull-out is not decisive in equation D.4 and D.5, FprEN 1992-4:2016 $N_{RK,p}$ must be replaced by $N^0_{RK,c}$.

TOX Highload Anchor SZ

Performance
Characteristic values under **fire exposure**

Annex C8

Table C10: Displacements under tension and shear load, **steel zinc plated**

Anchor size			10/ M6	12/ M8	15/ M10	18/ M12	24/ M16	24 /M16L	28/ M20	32/ M24
Tension load										
Tension load in cracked concrete	N	[kN]	2,4	5,7	7,6	12,3	17,1	21,1	24	26,2
Displacement	δ_{N0}	[mm]	0,5	0,5	0,5	0,7	0,8	0,7	0,9	1,4
	$\delta_{N\infty}$	[mm]	2,0	2,0	1,3	1,3	1,3	1,3	1,4	1,9
Tension load in uncracked concrete	N	[kN]	8,5	9,5	14,3	17,2	24	29,6	34	43
Displacement	δ_{N0}	[mm]	0,8	1,0		1,1		1,3	0,3	0,7
	$\delta_{N\infty}$	[mm]	3,4			1,7		2,3	1,4	0,7
Seismic action C2										
Displacement for DLS	$\delta_{N,eq(DLS)}$	[mm]	-	3,3	3,0	5,0	3,0	3,0	4,0	5,3
Displacement for ULS	$\delta_{N,eq(ULS)}$	[mm]	-	12,2	11,3	16,0	9,2	9,2	13,8	12,4
Shear load										
SZ-B										
Shear load in cracked and uncracked concrete	V	[kN]	9,1	14	20,7	35,1	52,1	52,1	77	86,6
Displacement	δ_{V0}	[mm]	2,5	2,1	2,7	3,0	5,1	5,1	4,3	10,5
	$\delta_{V\infty}$	[mm]	3,8	3,1	4,1	4,5	7,6	7,6	6,5	15,8
Seismic action C2										
Displacement for DLS	$\delta_{V,eq(DLS)}$	[mm]	-	2,3	3,1	3,0	2,6	2,6	1,6	6,1
Displacement for ULS	$\delta_{V,eq(ULS)}$	[mm]	-	4,8	6,4	6,1	6,6	6,6	4,8	9,5
SZ-S										
Shear load in cracked and uncracked concrete	V	[kN]	10,1	17,1	27,5	41,5	72	72	77	86,6
Displacement	δ_{V0}	[mm]	2,9	2,5	3,6	3,5	7,0	7,0	4,3	10,5
	$\delta_{V\infty}$	[mm]	4,4	3,8	5,4	5,3	10,5	10,5	6,5	15,8
Seismic action C2										
Displacement for DLS	$\delta_{V,eq(DLS)}$	[mm]	-	2,3	3,1	3,0	3,3	3,3	1,6	6,1
Displacement for ULS	$\delta_{V,eq(ULS)}$	[mm]	-	4,8	6,4	6,1	8,2	8,2	4,8	9,5
SZ-SK										
Shear load in cracked and uncracked concrete	V	[kN]	10,1	17,1	27,5	41,5	-	-	-	-
Displacement	δ_{V0}	[mm]	2,9	2,5	3,6	3,5	-	-	-	-
	$\delta_{V\infty}$	[mm]	4,4	3,8	5,4	5,3	-	-	-	-
Seismic action C2										
Displacement for DLS	$\delta_{V,eq(DLS)}$	[mm]	-	3,1	3,9	3,9	-	-	-	-
Displacement for ULS	$\delta_{V,eq(ULS)}$	[mm]	-	10,2	11,8	13,0	-	-	-	-

TOX Highload Anchor SZ

Performance
Displacements under tension and shear load, **steel zinc plated**

Annex C9

Table C11: Displacements under tension and shear load, **stainless steel A4**

Anchor size			12/M8	15/M10	18/M12	24/M16
Tension load						
Tension load in cracked concrete	N	[kN]	4,3	7,6	12,1	17,0
Displacement	δ_{N0}	[mm]	0,5	0,5	1,3	0,5
	$\delta_{N\infty}$	[mm]	1,2	1,6	1,8	1,6
Tension load in uncracked concrete	N	[kN]	7,6	11,9	16,7	24,1
Displacement	δ_{N0}	[mm]	0,2	0,3	1,2	1,5
	$\delta_{N\infty}$	[mm]	1,1	1,1	1,1	1,1
Seismic action C2						
Displacement for DLS	$\delta_{N,eq(DLS)}$	[mm]	4,7	4,5	4,3	4,9
Displacement for ULS	$\delta_{N,eq(ULS)}$	[mm]	13,3	12,7	9,7	10,1
Shear load						
Shear load in cracked concrete	V	[kN]	13,9	21,1	34,7	50,8
Displacement	δ_{V0}	[mm]	3,4	4,9	4,8	6,7
	$\delta_{V\infty}$	[mm]	5,1	7,4	7,1	10,1
Seismic action C2						
SZ-B, SZ-S						
Displacement for DLS	$\delta_{V,eq(DLS)}$	[mm]	2,8	3,1	2,6	3,3
Displacement for ULS	$\delta_{V,eq(ULS)}$	[mm]	5,6	5,8	5,0	6,9
SZ-SK						
Displacement for DLS	$\delta_{V,eq(DLS)}$	[mm]	2,5	2,8	2,9	-
Displacement for ULS	$\delta_{V,eq(ULS)}$	[mm]	5,8	5,9	6,9	-

TOX Highload Anchor SZ

Performance
Displacements under tension and shear load, **stainless steel A4**

Annex C10